

MANUFACTURERS
"AFC" LOGO
.030 MAX
RAISED OR INDENTED

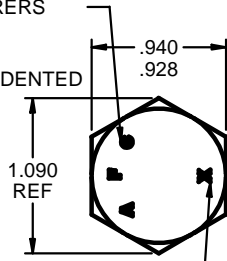

"X" ALLOY STEEL
GRADE MARK

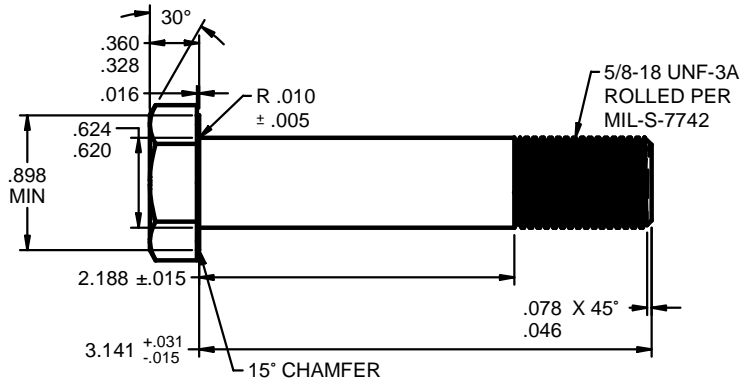

SCALE: 0.75X

DESIGN NOTES: AN10-30A AIRFRAME BOLT

1. LENGTH 3-9/64" (3.141"), GRIP 2-3/16" (2.188"), THREAD 5/8-18 UNF-3A.
2. PROCUREMENT SPECIFICATION NASM6812.
3. MATERIAL ALLOY STEEL PER PROCUREMENT SPECIFICATION.
UNS G40370 AMS6300 DFAR EXEMPT
UNS G87400 AMS6322 DFAR APPLIES
UNS G41400 AMS6382 DFAR APPLIES
UNS G41300 AMS-S-6758 DFAR APPLIES
4. HEAT TREAT AMS-2759 HRC 26-32.
5. FINISH CADMIUM PLATED PER AMS-QQ-P-416, TYPE 2 (YELLOW), CLASS 2.
6. THREADS 5/8-18 UNF-3A ROLLED PROCESS PER MIL-S-7742.
7. TENSILE 30,100 LBS. [133,891 N] MIN.
8. YIELD 23,080 LBS. [102,665 N] MIN.
9. SINGLE SHEAR 23,000 LBS. [102,309 N] MIN. SHORT LENGTH N/A.



ACTUAL SIZE

EXAMPLE PART NUMBER

AFC 10-30 C2 CADMIUM TYPE 2 YELLOW PLATING
AFC 10-30 C1 CADMIUM TYPE 1 PLAIN WHITE PLATING
AFC 10-30 TDC THERMAL DIFFUSION COATED ASTM A1059

↑ FINISH
↑ LENGTH 3.141"
↑ BODY SIZE & THREAD .625-18 UNF-3A
↑ MANUFACTURER AIRFASCO

UNCONTROLLED

CONFORMS TO: NASM3 THRU NASM20
PART NUMBER: AN10-30A

DIMENSIONS ARE IN INCHES AND TOLERANCES ARE AS SHOWN BELOW. DIMENSIONAL TOLERANCES AND SYMBOLS PER ANSI Y14.5M-1982	PROPRIETARY PARTS SHOWN IN THIS DRAWING ARE THE SUBJECT OF ISSUED UNITED STATES AND FOREIGN PATENTS AND PATENTS PENDING. UNAUTHORIZED REPRODUCTION AND/OR DISTRIBUTION OF THIS DRAWING IS STRICTLY PROHIBITED.		AIRFASCO.com 2655 HARRISON AVE SW, CANTON, OHIO 44706 USA	
	APPROVALS DRAWN M.B. DATE 2/19/15 CHECKED T.W. DATE 2/19/15 ENG APPR B.E. DATE 2/19/15 MGR APPR D.D. DATE 2/19/15		PART NUMBER: AN10-30A_AFC10-30C2 REV	
ANGLES ±5° .XX ±.03" .XXX ±.010" .XXXX ±.001"	SIZE A MATERIAL: 4037 / 8740 OR AS NOTED EST. WEIGHT: .331 / EACH LBS. [150.3 g]		SCALE: 0.75X DRAWING NUMBER: AN10-30A_AFC10-30C2 SHEET 1 OF 1	